

# RAK19003 WisBlock Mini Base Board Datasheet

## WisBlock Mini Base Overview

---

RAK19003 WisBlock Mini Base module is the new main board that allows you to attach WisBlock modules through the standardized expansion connectors. In addition, the WisBlock Mini Base module also comprises a Type-C USB connector, indicator LEDs, button, and sensor connectors.

If you can't find a module that fits your IoT requirements, use the standard connectors of WisBlock to develop your own specific function module. WisBlock supports open-source hardware architecture and you can find tutorials showing how to create your own [Awesome WisBlock](#)  module.

## Applications

- Wireless Sensor Network
- Environmental monitoring
- Wireless data transmission
- Data acquisition in the industrial environment
- Location and tracking of personnel or moving objects

## Main Features

- Flexible building block design, which enables modular function realization and expansion
- High-speed interconnection connectors in the WisBlock Base board to ensure the signal integrity
- Supports multiple types of low power MCUs
- Supports multiple types of sensors. A single board can support a combination of two different types of sensors
- Low power battery power supply
- Supports lithium battery charging
- Supports solar charging
- Fulfills Industrial level design
- Compact size: 30 x 35 mm

## Specifications

---

### Overview

**RAK19003** is a **WisBlock Base** board that connects **WisBlock Core** and **WisBlock Modules**. It provides the power supply and interconnection to the modules attached to it. It has one slot reserved for the WisBlock Core module and two Slot C-D for WisBlock Modules. The WisBlock Core is attached on the top side, and the WisBlock Modules are attached to the bottom side of the RAK19003 WisBlock Base board. Slot D holds modules up to 23 mm in size, while Slot C supports 10 mm WisBlock Modules. Also, there are two **2.54 mm pitch headers** for extension interface with **BOOT**, **I2C**, and **UART** pins.

For convenience, there is a Type-C USB connector that is connected directly to WisBlock Core MCU's USB port (if supported) or to a USB-UART converter depending on the WisBlock Core. It can be used for uploading firmware or serial communication. The USB-C connector is also used as a battery charging port.

WisBlock Modules are connected to the RAK19003 WisBlock Base board via **high-speed board to board connectors**. They provide secure and reliable interconnection to ensure the signal integrity of each data bus. A set of screws are used for fixing the modules, which makes it reliable even in an environment with lots of vibrations.

Using **RAK19003** as your WisBlock Base board, you can make your project compact, which is ideal in small enclosures. You can also use a [RAK19005 WisBlock Sensor Extension Cable](#) to position WisBlock Modules apart from the WisBlock Base board or in any part of your case.

## Board Overview

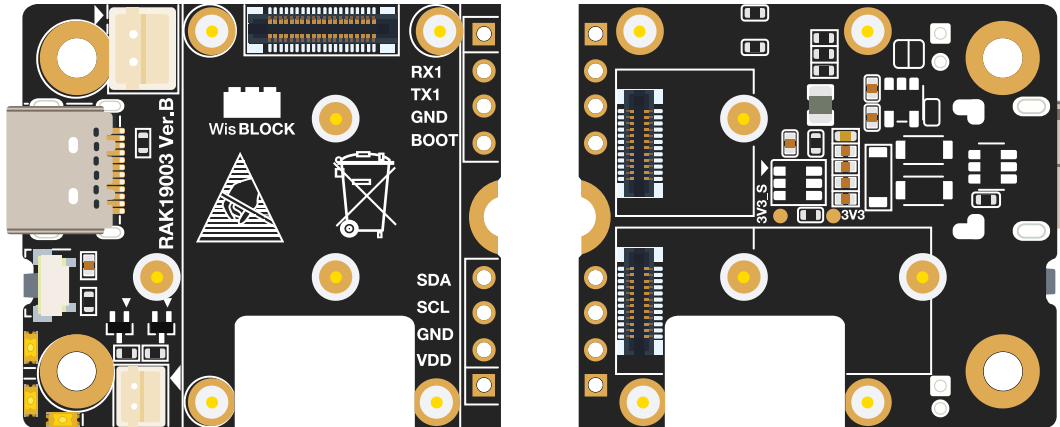

Figure 1: RAK19003 WisBlock Mini Base Top (Left) and Bottom (Right) View

## Block Diagram

The block diagram in **Figure 2** shows the internal architecture and external interfaces of the RAK19003 board.

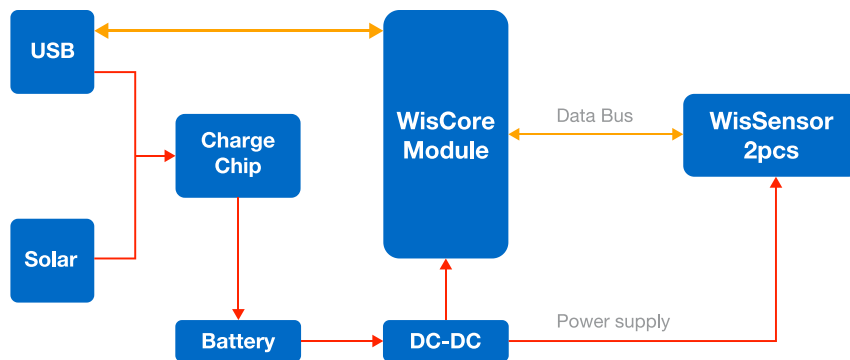

Figure 2: RAK19003 Mini Base Block Diagram

## Hardware

The hardware specification is categorized into six parts. It discusses the interfacing, pinouts, and their corresponding functions and diagrams. It also covers the electrical, mechanical, and environmental parameters that include the tabular data of the functionalities and standard values of the RAK19003 WisBlock Mini Base.

## Interfaces

RAK19003 WisBlock Mini Base provides the following interfaces, headers, button, and WisConnectors:

- 1 WisBlock Core module
- 2 WisBlock Modules compatible with Slot A-B
- 1 Type-C USB port for programming and debugging
- 3.7 V Rechargeable battery connector
- 5 V Solar Panel connector
- 2 Headers with BOOT, I2C, and UART pins accessible with solder contacts

Additionally, it has two user-definable LEDs - one power supply/charging indicator LED and a reset button.

**Figure 3** and **Figure 4** show the location of RAK19003 main components.

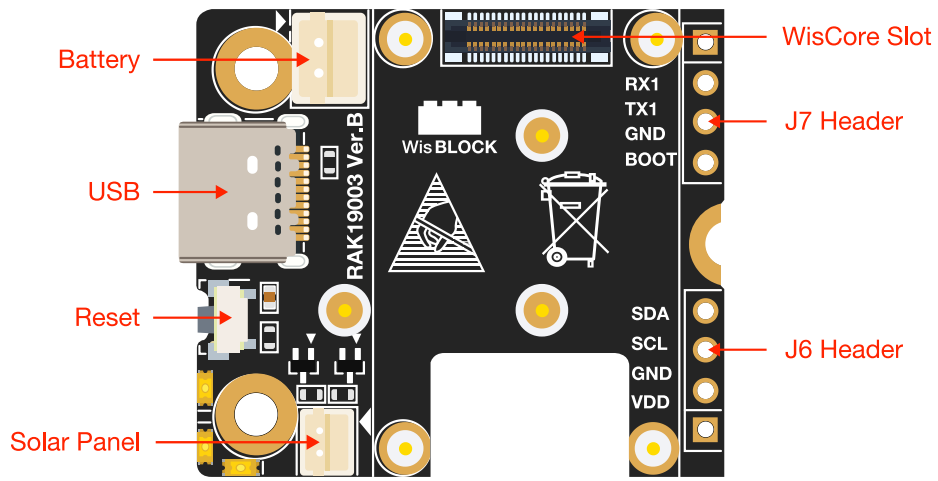

Figure 3: RAK19003 Top View Components

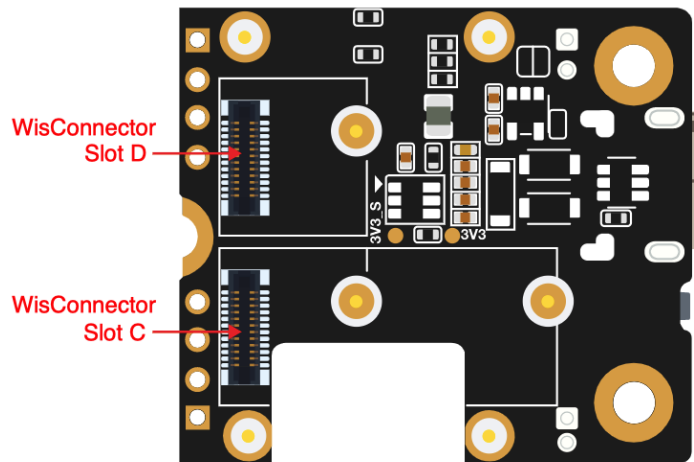

Figure 4: RAK19003 Bottom View Components

## Type-C USB port

The Type-C USB connector is compliant with the USB 2.0 specification. This USB interface directly communicates with the connected **WisBlock Core** module. It is also used as a charging input port for the battery. Here are some of the advantages of the Type-C USB connector:

- Smaller and reversible connector shape
- Port can be input or output
- Fast battery charging

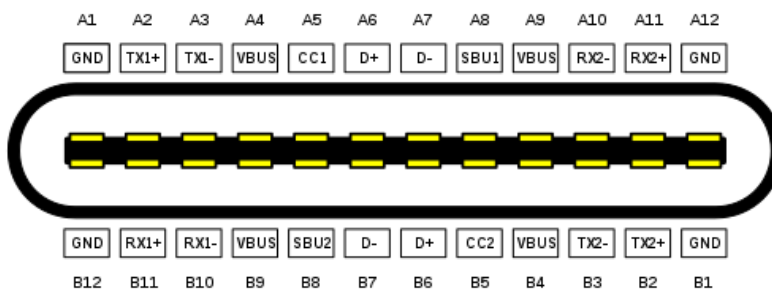

Figure 5: USB Type-C receptacle pinout

## J6 and J7 Headers

On the WisBlock Mini Base board, there are two 2.54 mm pitch headers for the IO extension. BOOT, I2C, and UART pins from the WisBlock Core module are also connected to these headers.

### J6 Header Pinout

Pin	Pin Name	Description
1	VDD	3.3 V
2	GND	Ground pin
3	SCL	I2C1 Clock
4	SDA	I2C1 Data

## J7 Header Pinout

Pin	Pin Name	Description
1	RX1	UART1 Rx pin
2	TX1	UART1 Tx pin
3	GND	Ground pin
4	BOOT	MCU Boot pin

### NOTE BOOT pin

BOOT pin is used on startup configuration or sequence of the WisBlock Core connected to it. It is commonly used for uploading the bootloader and/or application firmware. The requirements of the state of the BOOT pin depend on the specific model of the WisBlock Core used.

## Battery Connector

Figure 6 shows the battery connector V+(VBAT) and GND.

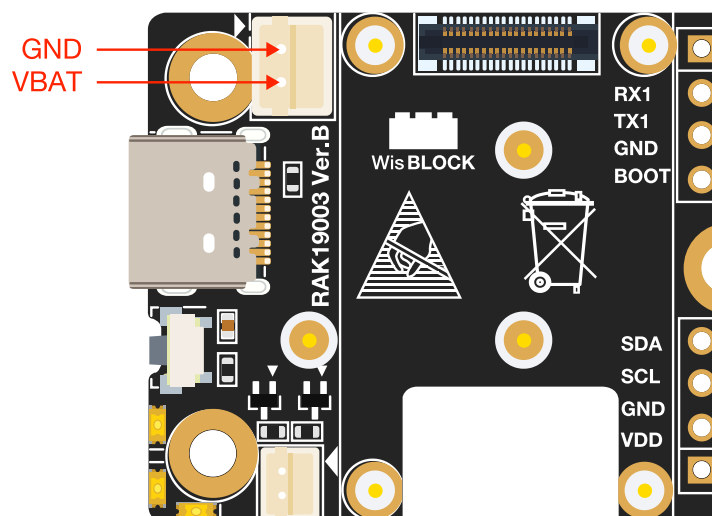

Figure 6: Battery Connector Pin Order

### WARNING

The voltage of the battery **must not exceed 4.3 V**.

## Solar Panel Connector

Figure 7 shows the solar panel connector V+(Vin) and GND.

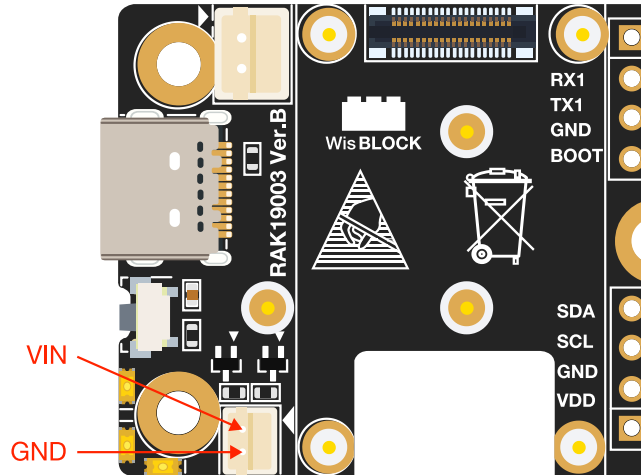

Figure 7: Solar Panel Connector V+ and GND

### ⚠ WARNING

The output voltage of the solar panel **must not exceed 5.5 V**. Otherwise, it may cause permanent damage to the board.

## LEDs

Three LEDs are used to indicate the operating status. Below are the functions of the LEDs:

- **Red LED** - Connected to the charger chip to indicate the charger status. When the battery is charging, this red LED is on. When the battery is full, this LED is weak light or off.
- **Green LED** - Connected to the MCU module, controlled by MCU defined by the user.
- **Blue LED** - Connected to the MCU module, controlled by MCU defined by the user.

## RESET Push Button

The Reset Push Button is connected to the MCU module. When pushed, it resets the MCU.

## Pin Definition

### Connector for WisBlock Core

The **WisCore module connector** is a 40-pin board-to-board connector. It is a high-speed and high-density connector, with an easy attaching mechanism.

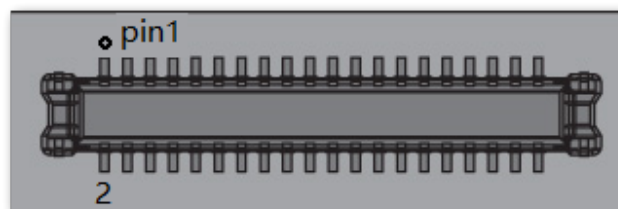

Figure 8: WisCore module connector

The table below shows the pinout of the 40-pin MCU module connector:

Pin Number	Function Name of WisBlock Base	Pin Number	Function Name of WisBlock Base
1	VBAT	2	VBAT
3	GND	4	GND
5	3V3	6	3V3
7	USB+	8	USB-
9	VBUS	10	SW1
11	TXD0	12	RXD0
13	RESET	14	LED1
15	LED2	16	LED3
17	VDD	18	VDD
19	I2C1_SDA	20	I2C1_SCL
21	AIN0	22	AIN1
23	BOOT0	24	IO7
25	SPI_CS	26	SPI_CLK
27	SPI_MISO	28	SPI_MOSI
29	IO1	30	IO2
31	IO3	32	IO4
33	TXD1	34	RXD1
35	I2C2_SDA	36	I2C2_SCL
37	IO5	38	IO6
39	GND	40	GND

As for the following table, it shows the definition of each pin of the WisBlock Core connector:

Pin Number	Pin Name	Type	Description
1	VBAT	S	Power supply from battery
2	VBAT	S	Power supply from battery
3	GND	S	Ground
4	GND	S	Ground
5	3V3	S	3.3 V power supply
6	3V3	S	3.3 V power supply
7	USB+	I/O	USB D+
8	USB-	I/O	USB D-
9	VBUS	S	USB VBUS
10	SW1	I/O	Not connected
11	TXD0	I/O	MCU UART0 TX signal
12	RXD0	I/O	MCU UART0 RX signal
13	RESET	I	Connected to the reset switch, for MCU reset
14	LED1	I/O	LED for battery charging indication
15	LED2	I/O	LED for custom usage
16	LED3	I/O	LED for custom usage
17	VDD	S	Generated by MCU module for power sensor board if the MCU IO level is not 3.3 V
18	VDD	S	Generated by MCU module for power sensor board if the MCU IO level is not 3.3 V
19	I2C1_SDA	I/O	The first set of I2C data signal
20	I2C1_SCL	I/O	The first set of I2C clock signal
21	AIN0	A	Analog input for ADC
22	AIN1	A	Analog input for ADC
23	BOOT0	I	For ST MCU only. The MCU will enter boot mode if this pin is connected to VDD.

Pin Number	Pin Name	Type	Description
24	IO7	I/O	Not connected
25	SPI_CS	I/O	SPI chip select signal
26	SPI_CLK	I/O	SPI clock signal
27	SPI_MISO	I/O	SPI MISO signal
28	SPI_MOSI	I/O	SPI MOSI signal
29	IO1	I/O	General purpose IO
30	IO2	I/O	Used for 3V3_S enable
31	IO3	I/O	General purpose IO
32	IO4	I/O	General purpose IO
33	TXD1	I/O	MCU UART1 TX signal
34	RXD1	I/O	MCU UART1 RX signal
35	I2C2_SDA	I/O	The second set of I2C data signal
36	I2C2_SCL	I/O	The second set of I2C clock signal
37	IO5	I/O	General purpose IO
38	IO6	I/O	General purpose IO
39	GND	S	Ground
40	GND	S	Ground

## Connectors for WisBlock Sensor

The WisBlock sensor module connector is a **24-pin board-to-board connector**.

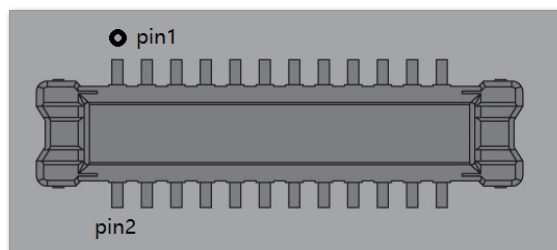

Figure 9: WisSensor module connector



 **NOTE**

There are two connectors reserved for the sensor modules on the RAK19003. The pinout definition of the WisBlock modules with 24-pin connector on WisBlock Mini Base varies according to its connector.

Connector C	Connector D	Pin Number	Pin Number	Connector C	Connector D
TXD1	TXD1	1	2	GND	GND
SPI_CS	SPI_CS	3	4	SPI_CLK	SPI_CLK
SPI_MISO	SPI_MISO	5	6	SPI_MOSI	SPI_MOSI
I2C1_SCL	I2C1_SCL	7	8	I2C1_SDA	I2C1_SDA
VDD	VDD	9	10	IO4	IO6
3V3_S	3V3_S	11	12	IO3	IO5
NC	NC	13	14	3V3_S	3V3_S
NC	NC	15	16	VDD	VDD
NC	NC	17	18	NC	NC
NC	NC	19	20	NC	NC
NC	NC	21	22	NC	NC
GND	GND	23	24	RXD1	RXD1

As for the following table, it shows the pin name and description of each pin in the WisSensor module connector.

Pin Number	Connector C	Connector D	Type	Description
1	TXD1	TXD1	I/O	UART TX signal
2	GND	GND	S	Ground
3	SPI_CS	SPI_CS	I/O	SPI chip select signal
4	SPI_CLK	SPI_CLK	I/O	SPI clock signal
5	SPI_MISO	SPI_MISO	I/O	SPI MISO signal
6	SPI_MOSI	SPI_MOSI	I/O	SPI MOSI signal
7	I2C1_SCL	I2C1_SCL	I/O	I2C clock signal
8	I2C1_SDA	I2C1_SDA	I/O	I2C data signal
9	VDD	VDD	S	Generated by CPU module. Used to power sensor board if MCU IO level is not 3.3 V
10	IO4	IO6	I/O	General purpose IO pin. When 3V3_S is used, this pin cannot be used as an interrupt input.
11	3V3_S	3V3_S	S	3.3 V power supply. This power pin is controlled by IO2 from the WisBlock Core module.
12	IO3	IO5	I/O	General purpose IO pin. When 3V3_S is used, this pin cannot be used as an interrupt input.
13	NC	NC	NC	Not connected
14	3V3_S	3V3_S	S	3.3 V power supply. This power pin is controlled by IO2 from the WisBlock Core module.
15	NC	NC	NC	Not connected
16	VDD	VDD	S	Generated by CPU module. Used to power sensor board if the MCU IO level is not 3.3 V.
17	NC	NC	NC	Not connected
18	NC	NC	NC	Not connected
19	NC	NC	NC	Not connected
20	NC	NC	NC	Not connected
21	NC	NC	NC	Not connected
22	NC	NC	NC	Not connected

Pin Number	Connector C	Connector D	Type	Description
23	GND	GND	S	Ground
24	RXD1	RXD1	I/O	UART RX signal

## Electrical Characteristics

### Absolute Maximum Ratings

The **Absolute Maximum Ratings** of the device are shown in the table below. The stress ratings are the functional operation of the device.

#### WARNING

1. If the stress rating goes above what is listed, it may cause permanent damage to the device.
2. Under the listed conditions is not advised.
3. Exposure to maximum rating conditions may affect the device reliability.

Ratings	Maximum Value	Unit
Power Supply on the USB port ( <b>VBUS</b> )	-0.3 to 5.5	V
Battery Voltage ( <b>VBAT</b> )	-0.3 to 4.3	V
Solar Panel Voltage ( <b>CONN_S</b> )	-0.3 to 5.5	V
IOs of WisConnector	-0.3 to VDD+0.3	V
ESD	2000	V

#### NOTE

The RAK19003, as any electronic equipment, is sensitive to **electrostatic discharge (ESD)**. Improper handling can cause permanent damage to the module.

## Current Consumption

The RAK19003 is designed for **low-power IoT products**. Its power supply uses a high-efficiency low ground current regulator. When there is no module on RAK19003, the **leakage current is lower than 2  $\mu$ A**. With WisBlock Core and WisBlock sensor on it, the sleep current is **lower than 10  $\mu$ A**. When a LoRa module is transmitting, the current may reach **130 mA**.

Conditions	Current	Unit
Leakage current, without any module on RAK19003	2	μA
Idle current, with WisBlock Core and WisBlock Modules in sleep mode	10	μA
Working current, with LoRa module transmitting	130	μA
Maximum output current	750	mA

## Battery Connector

The RAK19003 WisBlock Mini Base Board can be powered by a battery, connected to the **P2 connector**. The nominal operating voltage of the battery should be within the range shown in the following table. The matching connector for the battery wires is a [JST PHR-2 2 mm pitch female](#) 

Minimum	Typical	Maximum	Unit
3.3	3.7	4.3	V

The USB connector is used as a charging port. The voltage and current fed to the battery through the port should not exceed its charging limits, as shown in the table below.

Parameter	Value
Charging Voltage	4.5 – 5.5 V
Charging Current	350 mA

A suitable Li-Ion battery should have the following parameters as shown in the table below:

Parameter	Value
Standard Voltage	3.7 V
Charging Voltage	4.2 V
Capacity	As required
Discharge current	At least 500 mA

### NOTE

Don't use a non-rechargeable battery.

## Solar Panel Connector

A 5 V Solar Panel can be connected to the board via the **P1 connector**. The solar panel can also be used to charge the Li-Ion battery. The matching connector for the solar panel wires is a [JST ZHR-2 1.5 mm pitch female](#) 

# Mechanical Characteristics

## Board Dimensions

Figure 10 shows the detailed mechanical dimensions of RAK19003.

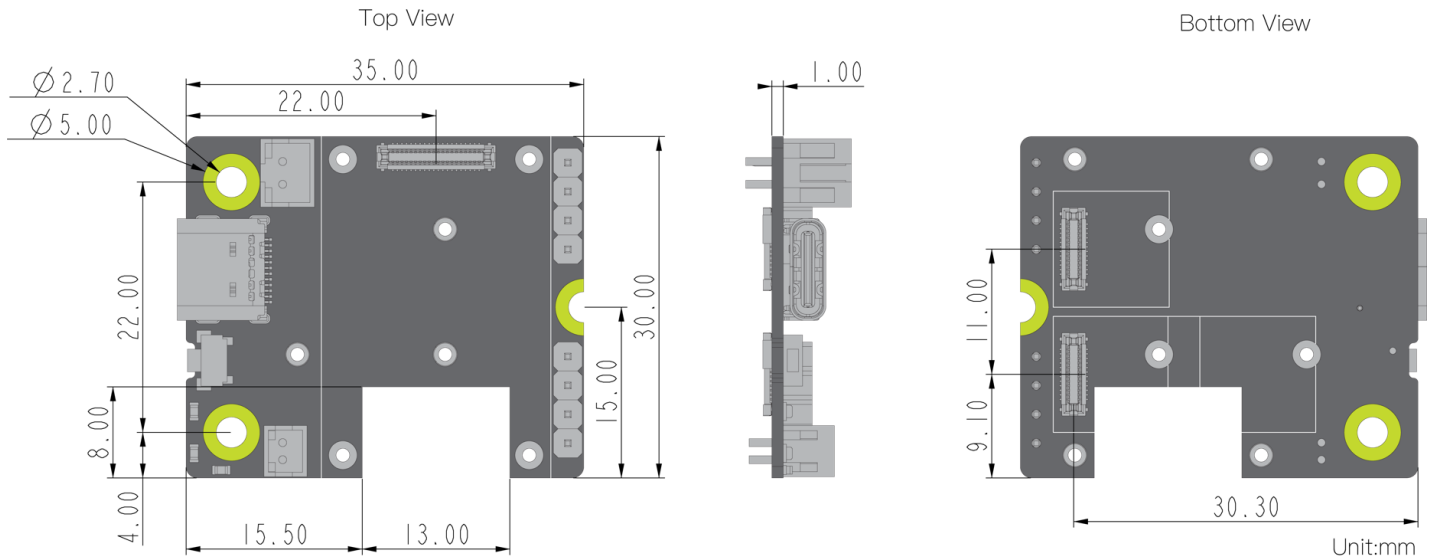

Figure 10: RAK19003 Mechanical Dimensions

Figure 11 and Figure 12 show the mounting holes location and diameter of the RAK19003 Board.

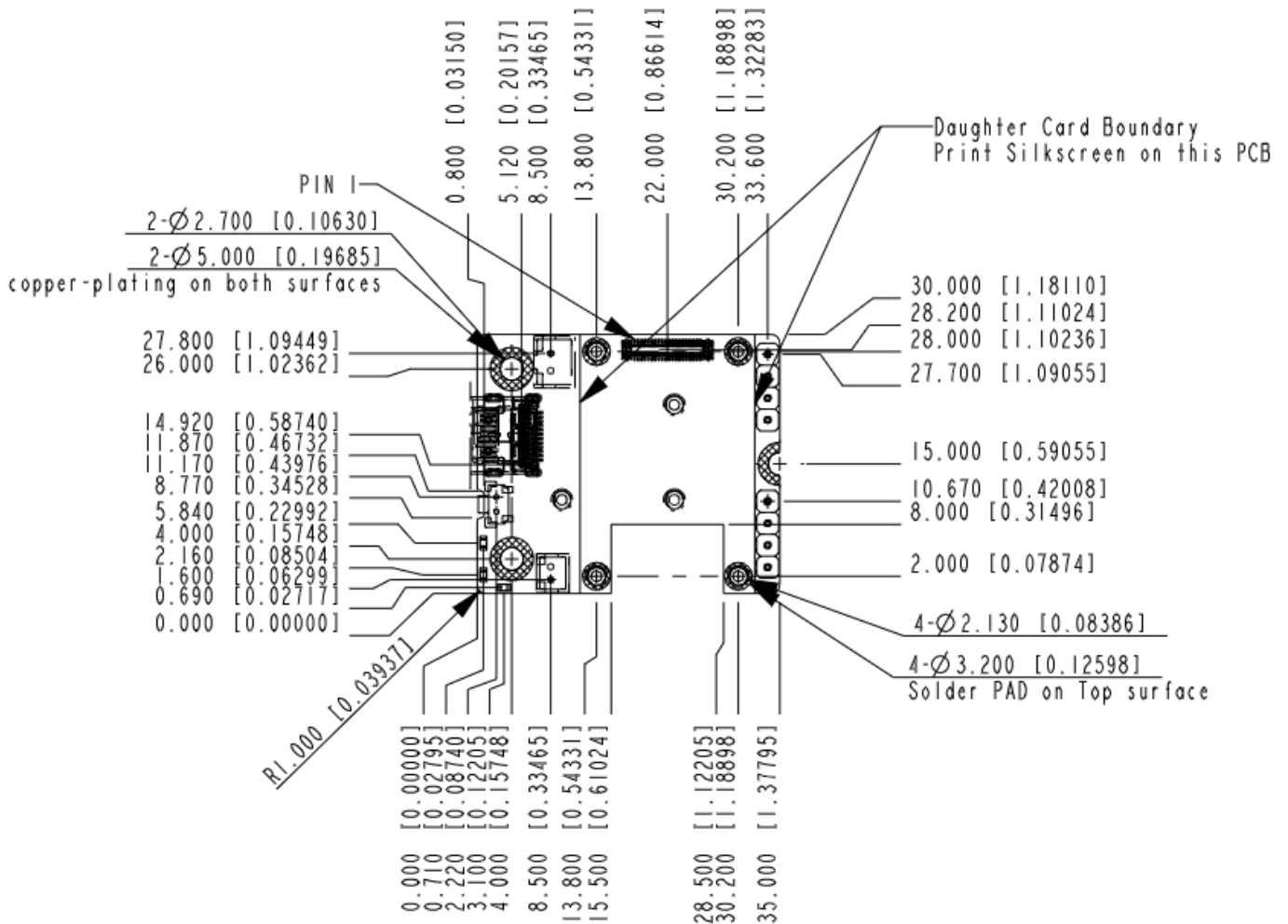
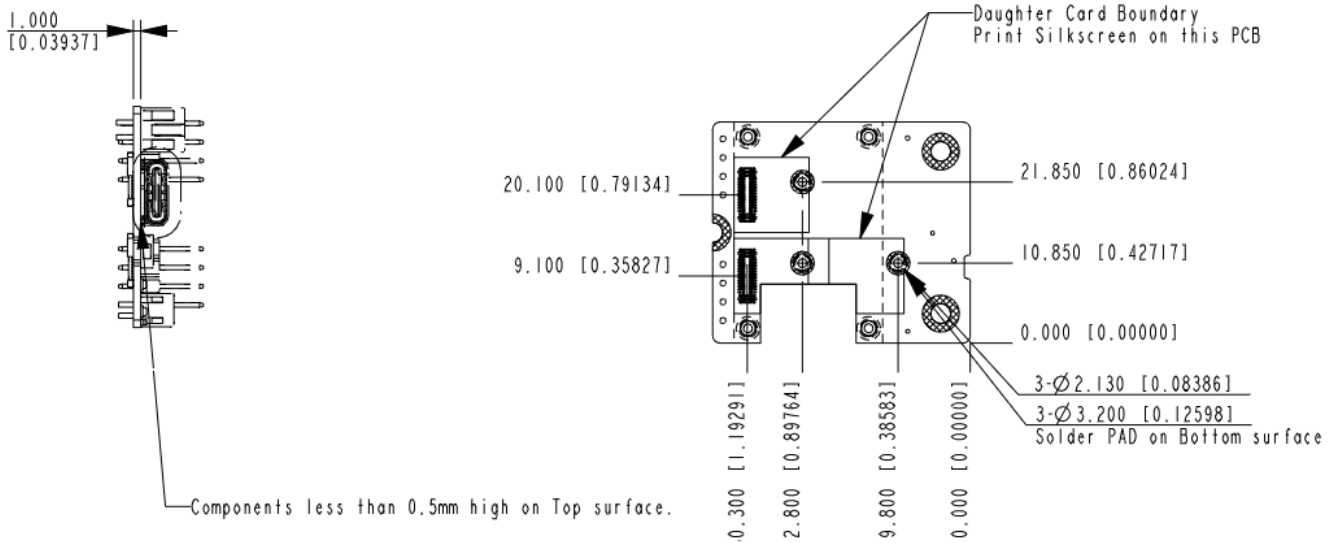

Figure 11: RAK19003 Mounting Holes Location and Diameter



- Notes:(unless otherwise specified)
1. The cross shadow area represents copper-plating on both surfaces, and the single shadow area represents keepout components, non-ground vias and route on this surface.
  2. Unit:mm(inch).

Figure 12: RAK19003 Mounting Holes Location and Diameter

## WisConnector PCB Layout

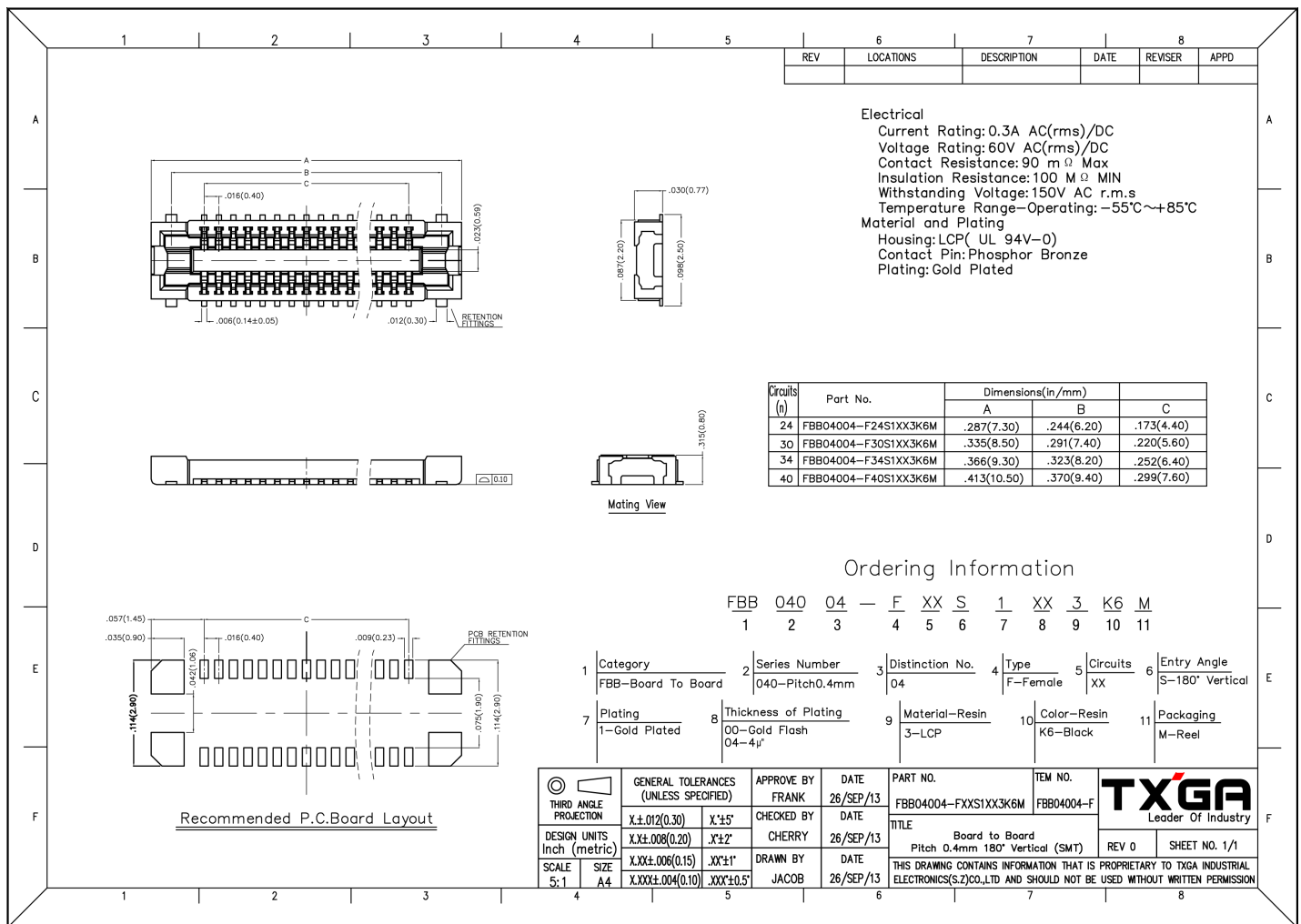

Figure 13: WisConnector PCB Footprint and Recommendations

## Environmental Characteristics

The table below lists the operation and storage temperature requirements of RAK5005-O:

Parameter	Minimum	Typical	Maximum
Operational Temperature Range	-35 °C	+25 °C	+75 °C
Extended Temperature Range	-40 °C	+25 °C	+80 °C
Storage Temperature Range	-40 °C	+25 °C	+80 °C

## Schematic Diagram

The component schematics diagram of the RAK19003 is shown in **Figure 14** and **Figure 15**.

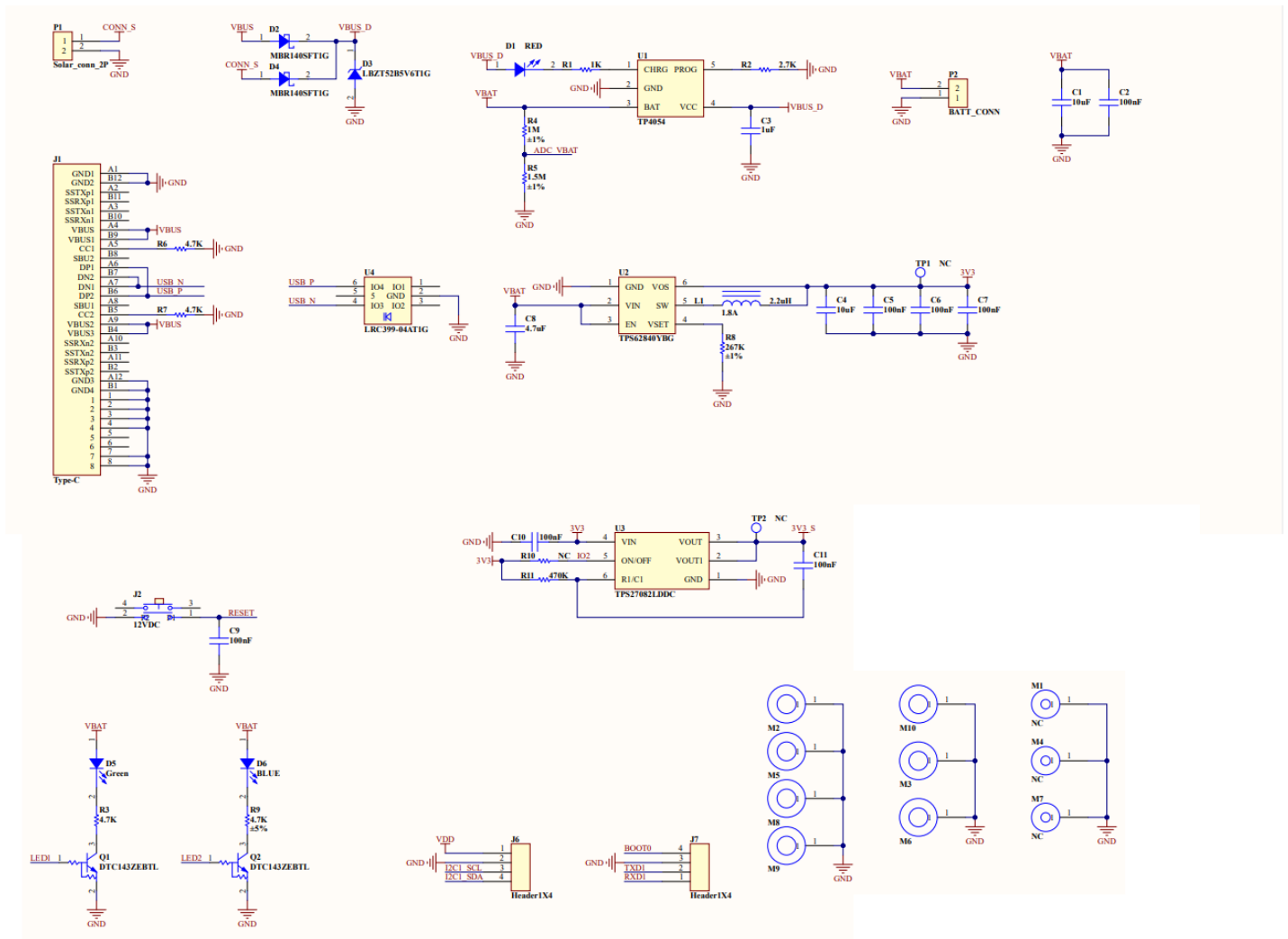

Figure 14: RAK19003 Schematic Diagram

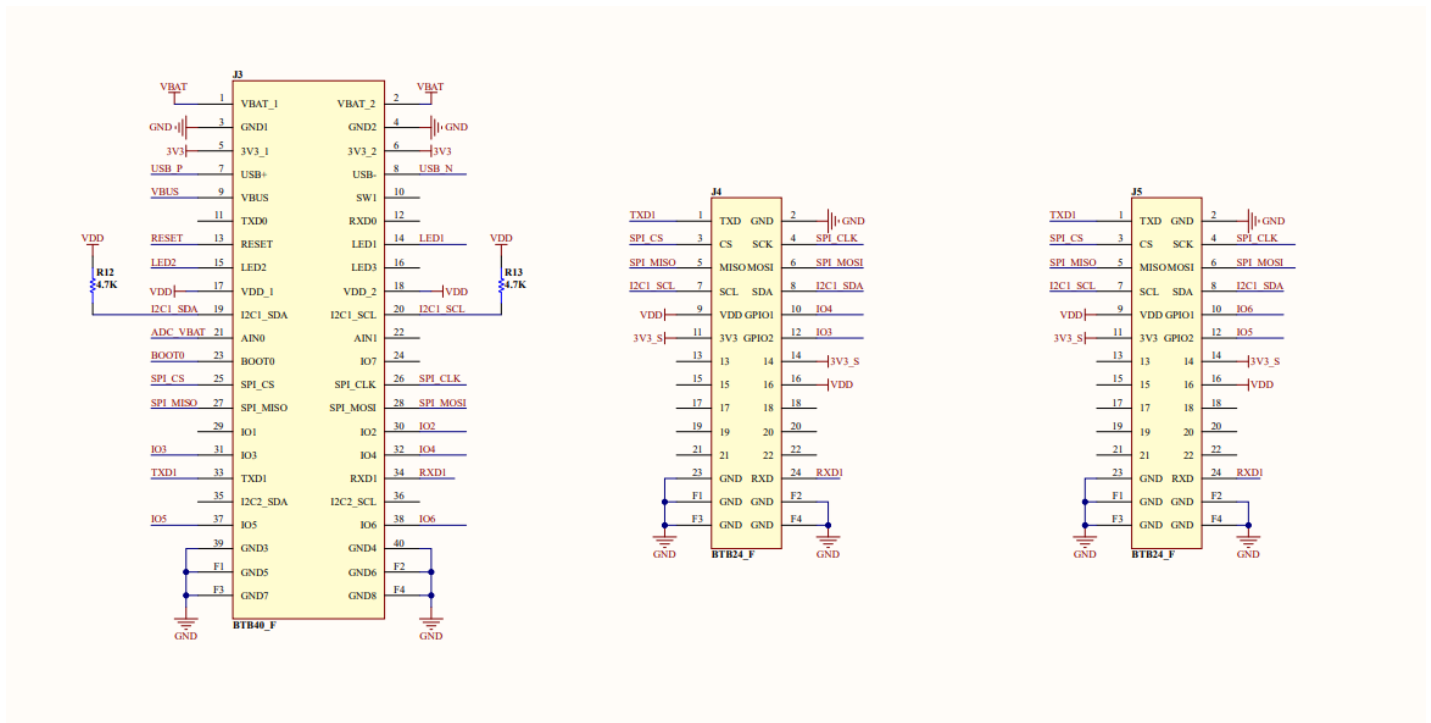

Figure 15: RAK19003 Schematic Diagram (Connectors)